

**SUPERHOIST™
SUPERDECK®**

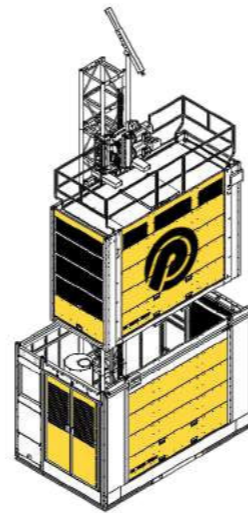

SH2332\2340



SPECIFICATIONS

Capacity (kg)	2300
Max height (m)	75
Max speed (m\minute)	36

DIMENSIONS

Car Length Internal (2340 model)	3080 (3880)
Car Width Internal	1520
Car Height Internal	2550
Ground enclosure Length Internal (2340 model)	3580 (4380)
Ground enclosure Width Internal	2690
Ground enclosure Height Internal	3120

FEATURES

Ground enclosure	Included
C-gate	Included
Control system option	Touch Panel
Programmable landings (floor opt out)	Yes
Elevator simulation option	Yes
Autogrease option	Yes
High Speed option (72 m/min)	No
Super speed option (92 m/min)	No
Wide Body option	No
RX control - Data logging (real time)	Yes
Motor drive	2
Power - Hoist motors	400v 3 phase, 63A
Power - on top deck	230v
AS-1 bus hoist call	Yes
Wind meter option	Yes
Jib for self climb option	Yes

SH2740\2745

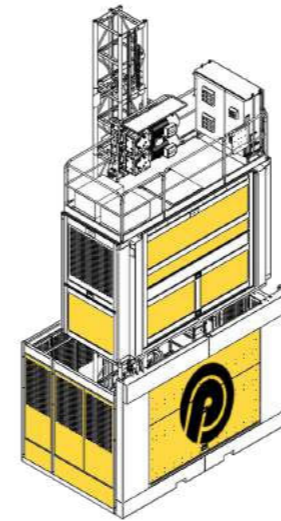

SPECIFICATIONS

Capacity (kg)	2700
Max height (m)	400
Max speed (m\minute)	72

DIMENSIONS

Car Length Internal (2745 model)	3900 (4400)
Car Width Internal	1520
Car Height Internal	2600
Ground enclosure Length Internal (2745 model)	4310 (4810)
Ground enclosure Width Internal	2690
Ground enclosure Height Internal	3120

FEATURES

Ground enclosure	Included
C-gate	Included
Control system option	Touch Panel
Programmable landings (floor opt out)	Yes
Elevator simulation option	Yes
Autogrease option	Yes
High Speed option (72 m/min)	No
Super speed option (92 m/min)	No
Wide Body option	Yes
RX control - Data logging (real time)	Yes
Motor drive	2
Power - Hoist motors	400v 3 phase, 160A
Power - on top deck	230v
AS-1 bus hoist call	Yes
Wind meter option	Yes
Jib for self climb option	Yes

SH3240\3645

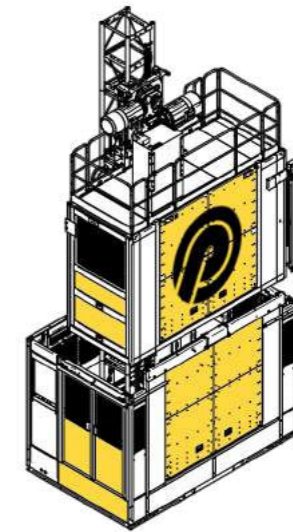

SPECIFICATIONS

Capacity (kg)	3200
Max height (m)	400
Max speed (m\minute)	92

DIMENSIONS

Car Length Internal (3245 model)	3900 (4400)
Car Width Internal	1520
Car Height Internal	2600
Ground enclosure Length Internal (3245 model)	4310 (4810)
Ground enclosure Width Internal	2690
Ground enclosure Height Internal	2940

FEATURES

Ground enclosure	Included
C-gate	Included
Control system option	Touch Panel
Programmable landings (floor opt out)	Yes
Elevator simulation option	Yes
Autogrease option	Yes
High Speed option (72 m/min)	No
Super speed option (92 m/min)	No
Wide Body option	No
RX control - Data logging (real time)	Yes
Motor drive	2 or 3
Power - Hoist motors	400v 3 phase, 200A
Power - on top deck	230v
AS-1 bus hoist call	Yes
Wind meter option	Yes
Jib for self climb option	Yes

SH4555



SPECIFICATIONS

Capacity (kg)	4500
Max height (m)	400
Max speed (m\minute)	92

DIMENSIONS

Car Length Internal	5400
Car Width Internal	1520
Car Height Internal	2900
Ground enclosure Length Internal	N/A
Ground enclosure Width Internal	N/A
Ground enclosure Height Internal	2940

FEATURES

Ground enclosure	Optional
C-gate	Included
Control system option	Touch Panel
Programmable landings (floor opt out)	Yes
Elevator simulation option	Yes
Autogrease option	Yes
High Speed option (72 m/min)	No
Super speed option (92 m/min)	Yes
Wide Body option	No
RX control - Data logging (real time)	Yes
Motor drive	4
Power - Hoist motors	400v 3 phase, 250A
Power - on top deck	230v
AS-I bus hoist call	Yes
Wind meter option	Yes
Jib for self climb option	Yes

SH5562

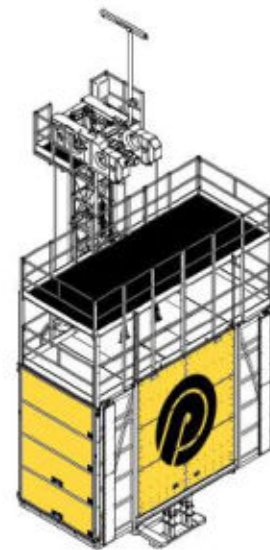

SPECIFICATIONS

Capacity (kg)	5500
Max height (m)	400
Max speed (m\minute)	92

DIMENSIONS

Car Length Internal (2340 model)	6120
Car Width Internal	2500
Car Height Internal	3350
Ground enclosure Length Internal	N/A
Ground enclosure Width Internal	N/A
Ground enclosure Height Internal	N/A

FEATURES

Ground enclosure	Optional
C-gate	Included
Control system option	Touch Panel
Programmable landings (floor opt out)	Yes
Elevator simulation option	Yes
Autogrease option	Yes
High Speed option (72 m/min)	No
Super speed option (92 m/min)	Standard
Wide Body option	N/A
RX control - Data logging (real time)	Yes
Motor drive	3
Power - Hoist motors	400v 3 phase, 200A
Power - on top deck	230v
AS-I bus hoist call	Yes
Wind meter option	Yes
Jib for self climb option	Yes

SHTWIN MAST



SPECIFICATIONS

Capacity (kg)	4000
Max height (m)	400
Max speed (m\minute)	36

DIMENSIONS

Car Length Internal (2340 model)	4900
Car Width Internal	3040
Car Height Internal	2600
Ground enclosure Length Internal	N/A
Ground enclosure Width Internal	N/A
Ground enclosure Height Internal	N/A

FEATURES

Ground enclosure	Optional
C-gate	No
Control system option	Touch Panel
Programmable landings (floor opt out)	Yes
Elevator simulation option	Yes
Autogrease option	Yes
High Speed option (72 m/min)	No
Super speed option (92 m/min)	No
Wide Body option	N/A
RX control - Data logging (real time)	Yes
Motor drive	2x2
Power - Hoist motors	400v 3 phase, 160A
Power - on top deck	230v
AS-I bus hoist call	Yes
Wind meter option	Yes
Jib for self climb option	Yes

SUPERDECK® LOADING PLATFORM

Designed to simplify the handling of materials, particularly on multi-storey construction sites, this revolutionary Preston Hire innovation offers a 'drawer-like' loading platform system which has dramatically increased safety and reduced crane operation time for customers around the world.

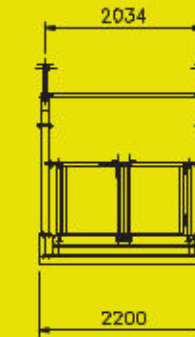

2.2m

DIMENSIONS & SPECS

Overall Platform Length (extended mm)	8500
Platform Width (overall/internal mm)	2200/1653
Height to top of Handrails (mm)	1202
Height to top of Screw Jack (high/low mm)	3600/2450
H Frame (front distance outboard from slab edge mm)	1400
Tare Weight (kg)	2500
Capacity (Max load kg)	5000

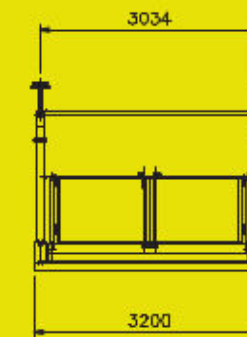

3.2m

DIMENSIONS & SPECS

Overall Platform Length (extended mm)	8500
Platform Width (overall/internal mm)	3200/2653
Height to top of Handrails (mm)	1202
Height to top of Screw Jack (high/low mm)	3600/2450
H Frame (front distance outboard from slab edge mm)	1400
Tare Weight (kg)	3000
Capacity (Max load kg)	5000

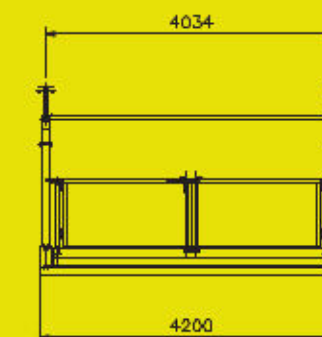

4.2m

DIMENSIONS & SPECS

Overall Platform Length (extended mm)	8500
Platform Width (overall/internal mm)	4200/3653
Height to top of Handrails (mm)	1202
Height to top of Screw Jack (high/low mm)	3600/2450
H Frame (front distance outboard from slab edge mm)	1400
Tare Weight (kg)	3500
Capacity (Max load kg)	5000



0800 440 558 | prestonhire.co.nz